

The National Albacore Association
UK National Championship 2011
July 2/3/4th 2011

Llandudno Sailing Club

Sailing Instructions

The Championships will be sailed to the principles of the RYA Racing Charter

1 RULES

- 1.1 The Championships will be governed by the rules as defined in *The Racing Rules of Sailing*.
- 1.2 Racing rule 40 will be changed as follows;
Personal Flotation Devices – competitors shall wear personal flotation devices at all times when afloat except briefly while changing or adjusting clothing or personal equipment.
Wet suits or dry suits are not personal flotation devices. This changes the Part 4 preamble. Flag Y will not be displayed.

2 NOTICES TO COMPETITORS

Notices to competitors will be posted on the Official Notice Board in the clubhouse

3 CHANGES TO SAILING INSTRUCTIONS

Any change to the sailing instructions (S.I's) will be posted before 1 hour before the first warning signal on the day it will take effect, on the official notice board, except that any change to the schedule of races will be posted by 20.00hrs on the day before it will take effect.

4 SIGNALS MADE ASHORE

- 4.1 Signals made ashore will be displayed at the head of the slipway adjacent to the Imperial Hotel.
- 4.2 When flag AP is displayed ashore, '1 minute' is replaced with 'not less than 45 minutes' in the race signal AP.
- 4.3 IC Flag D will be displayed with 1 sound signal to allow the fleet to launch.

5 SCHEDULE OF RACES

- 5.1 Dates of racing: Saturday 2nd to Monday 4th July 2011
- 5.2 The scheduled time of the warning signal for the first Points race of each day is

RACE	DATE	WARNING SIGNAL	TIME OF HIGH WATER
Points Race 1	Sat 2nd	11.55 hrs	12.09
Points Race 2	Sat 2nd	Follows Race 1	
Points Race 3	Sun 3rd	10.55 hrs	12.51
Points Race 4	Sun 3rd	Follows Race 3	
Points Race 5	Sun 3rd	Follows Race 4	
Points Race 6	Mon 4th	10.55 hrs	13.33
Points Race 7	Mon 4th	Follows Race 6	

- The second and subsequent races on each day will be held back to back with the first and previous races.
- 5.4 After a long postponement, to alert boats that a race or sequence of races will begin soon, an orange flag will be displayed with one sound signal for at least four minutes before a warning signal is displayed.

- 5.5 On the last day of the regatta no warning signal will be made after 15.00 hrs.
- 5.6 There will be a competitors briefing at 11.00 hrs on Saturday 2nd July at the beach masters motor home at the Imperial slipway.

6 CLASS FLAGS

The warning signal will be the Albacore Class flag unless otherwise indicated at the briefing.

7 RACING AREAS

The racing area will be the waters of Llandudno Bay.

8 THE COURSES

- 8.1 The course will be as per Appendix A , Course A and Course B. The diagrams in Appendix A to these Instructions show the course, the order in which marks are to be passed, and the side on which each mark is to be left..
The RC will display IC Numeral 1 for Course A and IC Numeral 2 for Course B. These signals will be displayed before the warning signal.
- 8.2 No later than the warning signal, the race committee signal boat may display the approximate compass bearing of the first leg.

9 MARKS

- 9.1 The course marks will be – yellow inflatable pillar marks
The starting and finishing marks will be – dan bouys with orange/blue flags
- 9.2 New marks as provided in instruction 11.1 will be yellow inflatable cylindrical.
- 9.3 A race committee boat signalling a change of a leg of the course is a mark as provided in instruction 12.2.

10 AREAS THAT ARE OBSTRUCTIONS

There are no obstructions.

11 THE START

- 11.1 The starting line will be between the committee boat displaying an orange flag and the pin end mark displaying an orange flag.

12 CHANGE OF THE NEXT LEG OF THE COURSE

- 12.1 Boats shall pass between the race committee boat signalling the change of the next leg and the nearby mark.

13 THE FINISH

The finishing line will be between the Committee Boat flying a blue flag and a dan buoy flying a blue flag.

At the discretion of the Race Officer, boats that are expected to finish the full course outside the time limit may finish at another mark. In this case an official boat will display flag W with two sounds, boats which have not rounded the nearby mark shall finish between this mark and the mast on the committee boat displaying flag W.

When a boat finishes in accordance with this instruction at the Flag W mark, she shall be given a finishing place after all boats which complete more legs of the course and then finish.

Boats which are lapped can be finished with the lead boat and awarded position at the discretion of the race officer.

14 PENALTY SYSTEM

- 14.1 As provided in RRS 67, the protest committee may, without a hearing, penalize a boat that has broken rule 42.
- 14.2 When a competitor has taken either a one turn or two turn penalty (noting race number and leg of course), or has retired after finishing (RET), each helm or crew shall complete the declaration on the sign off sheet within her protest time limit, situated at the Beachmaster's motorhome near the main slipway.
- 14.3 The Scoring Penalty, Rule 44.3, will not apply.

14.3 RYA Arbitration

14.3.1 When a protest or request for redress is lodged, a boat may at the same time request RYA Arbitration, or the protest committee or race committee may offer it.

14.3.2 If the parties and a member of the protest or race committee agree that RYA Arbitration is suitable, an arbitrator (who may be that member of the protest committee) will call a hearing conforming to Section B of Part 5 of the Racing Rules of Sailing, except that rule 64.1(a) will not apply. Instead, when the arbitrator decides that a boat that is a party to the arbitration hearing has broken a rule for which the Exoneration Penalty is available, the party will be invited to accept that penalty, and, if it is accepted by a protested boat, the protesting boat will be allowed to withdraw the protest, changing rule 63.1.

14.3.3 When there is not an agreement to use RYA Arbitration, or when, after RYA Arbitration, a protest is not withdrawn or the Exoneration Penalty is not applicable to the facts, there will be a normal protest hearing, at which the arbitrator may be a member of the protest committee. Rule 66 will not apply to the arbitration decision. A boat may still accept an Exoneration Penalty at any time before the start of a protest hearing and receive its protection from further penalization. She may also retire.

14.3.4 When redress is offered and accepted at the RYA Arbitration, the protest committee or race committee may seek to have this reviewed by asking for a full hearing. When redress is offered and not accepted, or not offered at all, the boat may have her request heard before a protest committee.

14.3.5 The Exoneration penalty for the RYA Arbitration procedure shall be a 20% scoring penalty.

15 TIME LIMITS

15.1 Time limits are as follows: For each race 90 minutes. When the first boat finishes within the last 30 minutes of that time, the Time Limit will be extended to 30 minutes after the finishing time of the first boat. No boat shall finish after the expiry of the time limit. This adds to RRS35.

If no boat has passed Mark 1 within 30 minutes the race will be abandoned. Failure to meet the target time will not be grounds for redress This changes Rule 62.1(a)

16 PROTESTS AND REQUESTS FOR REDRESS

16.1 Protest forms are available at the Race Office and the beachmaster's motorhome. Protests and requests for redress or reopening shall be delivered to the Race Office in the clubhouse within the appropriate time limit.

16.2 The protest time limit is 60 minutes after the last boat has finished the last race of the day. This will be displayed at the beachmaster's motorhome.

16.3 Notices will be posted on the Official Notice Board, within 30 minutes after the protest time limit to inform competitors of hearings in which they are parties or named as witnesses. Hearings will be held in the Protest Room. The approximate times for Protest meetings will be posted on the official notice board.

16.4 Notices of protests by the race committee or protest committee will be posted to inform boats under RRS 61.1(b).

16.5 A list of boats that, under instruction 14.1 have been penalised for breaking rule 42 will be posted .

Breaches of instructions 1.2, 14.1, 17.3b,18, 21 and 23, will not be grounds for a protest by another boat. This changes RRS 60.1(a). Penalties for these breaches may be less than disqualification if the protest committee so decides.

16.7 On the last day of the regatta a request for reopening a hearing shall be delivered

(a) within the protest time limit if the party requesting reopening was informed of the decision on the previous day.

(b) no later than 30 minutes after the party requesting reopening was informed of the decision on that day.

This changes RRS66.

17 SCORING

17.1 The Low Point System of Appendix A will apply unmodified.

17.2 If 7 races are sailed, a boats series score will be her 6 best scores. If 6 races are sailed, a boats series score will be her 5 best scores. If 5 races are sailed, a boats series score will be her 4 best scores. If 4 or fewer races are sailed, a boats series score will comprise of all the races sailed.

18 SCORING

18.1 Tally System – The Personal Identification Tally Number will be written on a Tally wrist band. The helm and crew must tally out by taking his /her Tally wrist band with him / her afloat visibly displayed on his / her wrist. Tallies can only be taken when released by the Beach Master. Tallies must be returned to the tally board immediately when coming ashore and not later than 10 minutes of the last boat coming ashore. The crew of a boat that does not intend to finish shall make every effort to notify the Committee Boat, a Safety Boat or a Mark Boat of his / her intentions. The crew of any boat retiring from a race and coming ashore should report to the Beach Master as soon as possible. It is the sole responsibility of the helm and crew to ensure that they have tallied correctly. Failure to comply with this Sailing Instruction will result in disqualification without a hearing and or a fine of £20 payable to the local branch of the RNLI, at the sole discretion of the Race Committee. This alters RRS 63.

18.3 A boat that retires from a race shall notify the race committee as soon as possible.

19 EQUIPMENT INSPECTION

A boat may be inspected at any time for compliance with the class rules and sailing instructions.

20 ENVIRONMENT

Any boat, observed by a member of Race Committee or patrol teams, discharging trash/rubbish into the water, after a hearing called in accordance with RRS 60.2 and 60.3, will be penalized, at the discretion of the Race Committee.

21 OFFICIAL BOATS

The official boats will be described on the Official Notice Board before the first race.

22 SUPPORT BOATS

Support boats are not allowed.

23 RADIO COMMUNICATION

A boat shall neither make radio transmissions while racing nor receive radio communications not available to all boats. This restriction also applies to mobile telephones.

24 PRIZES

24.1 Prizes will be awarded by the Albacore Class Association.

25 DISCLAIMER OF LIABILITY

NOR 16. Competitors participate in the regatta entirely at their own risk. See Rule 4, Decision to race. The organising authority will not accept any liability for material damage or personal injury or death sustained in conjunction with or prior to, during, or after the regatta.

26 INSURANCE

Each participating boat shall be insured with valid third-party liability insurance with a minimum cover of £2 million per event or the equivalent.

Appendix A: Course A

The full course will comprise 4 (four) rounds plus a finishing leg. Mark 1 is the intended windward mark. Marks 2 and 3 may not be laid until after the start. If laid mark 3, intended leeward mark, will not rank as a mark of the course on the first leg.

1. Round 1, 3 leave marks 1, 2, 3 to port
2. Round 2, 4 leave marks 1 and 3 to port
3. Repeat for the number of rounds displayed, then finish.
3. Start below leeward mark 3 (if laid)
4. The approximate internal angle between legs of the triangle will be 60°
5. The finishing leg is from mark 3 to the finishing line.

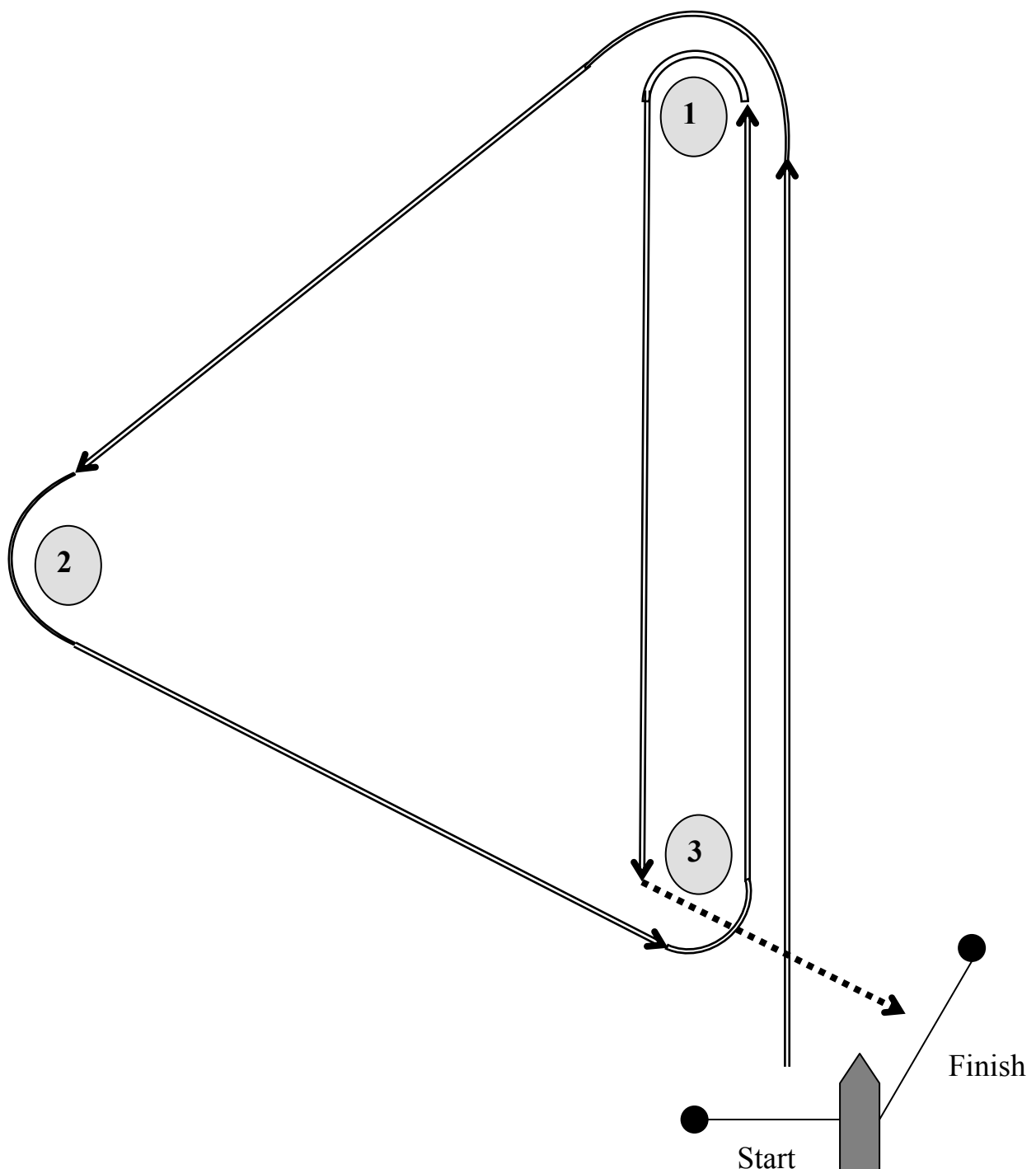

Appendix A: Course B

The full course will comprise 3 (three) rounds plus a finishing leg. Mark 1 is the intended windward mark. Marks 2 and 3 may not be laid until after the start. If laid mark 3, intended leeward mark, will not rank as a mark of the course on the first leg.

1. For each round, leave marks 1, 2, 3 to port
2. Repeat for the number of rounds displayed, then finish.
3. Start below leeward mark 3 (if laid)
4. The approximate internal angle between legs of the triangle will be 60°
5. The finishing leg is from mark 3 to the finishing line.

